

HD2LVDS01 (HDMI to RGB/LVDS) Adapter Instruction

V1.3 2026-04-01

Features

- Suitable for converting HDMI input signals to TTL RGB or LVDS outputs, with a maximum bandwidth of up to 340MHz
- HDMI input supports multiple resolutions such as 720P, 1080P, 4K@30, etc.
- Built-in EDID data, the preferred resolution can be set through the serial port
- The output can be selected as RGB or LVDS through the serial port or on-board resistors
- With backlight control, when the output is LVDS signal, the screen can be directly lit up
- With 3.5mm headphone output, analog stereo output can be output
- DC12V power supply via 5521 Jack, the board power consumption is less than 1.5W
- **HDCP is not supported**

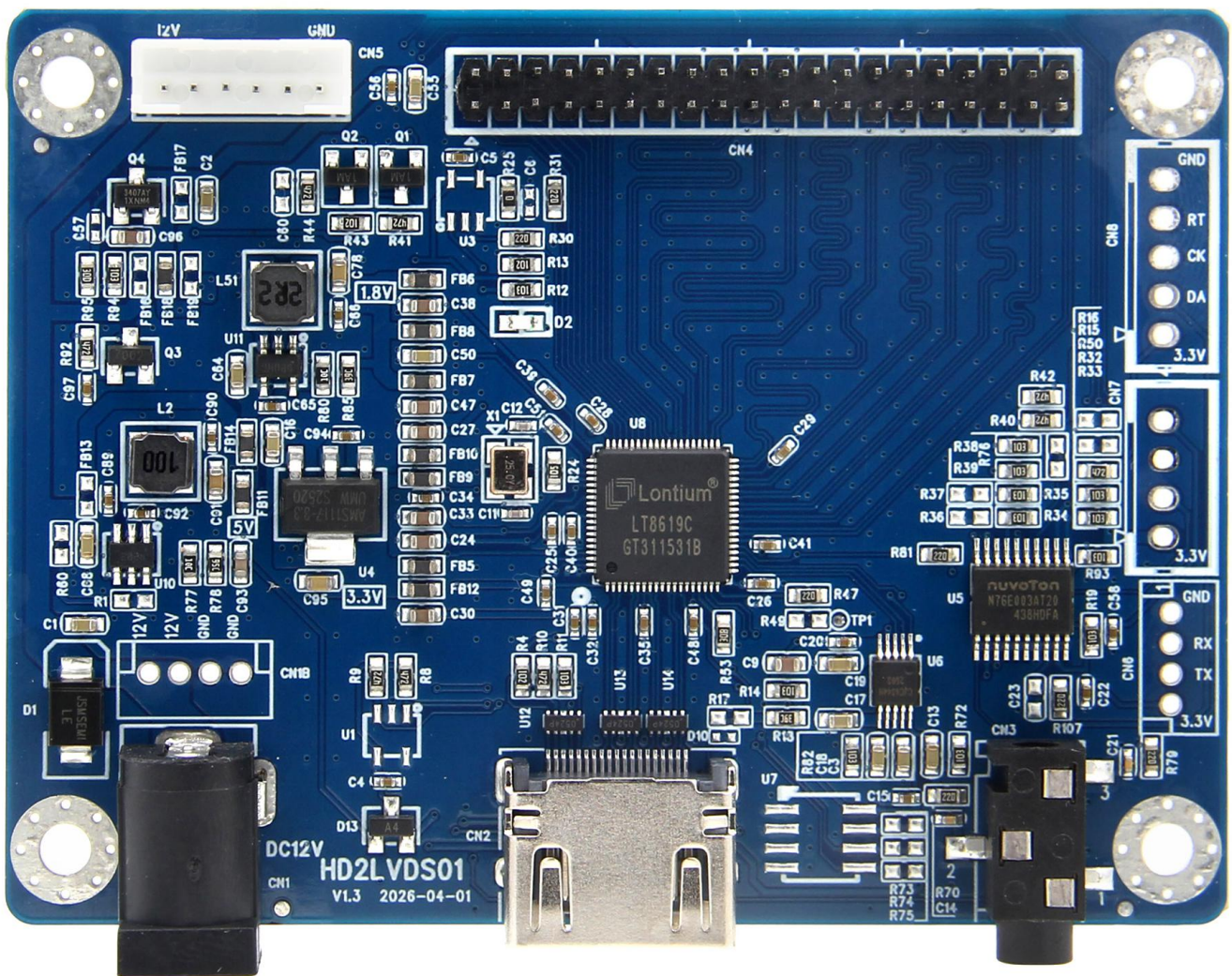

Figure 1: Board (8x6cm)

Interface definition:

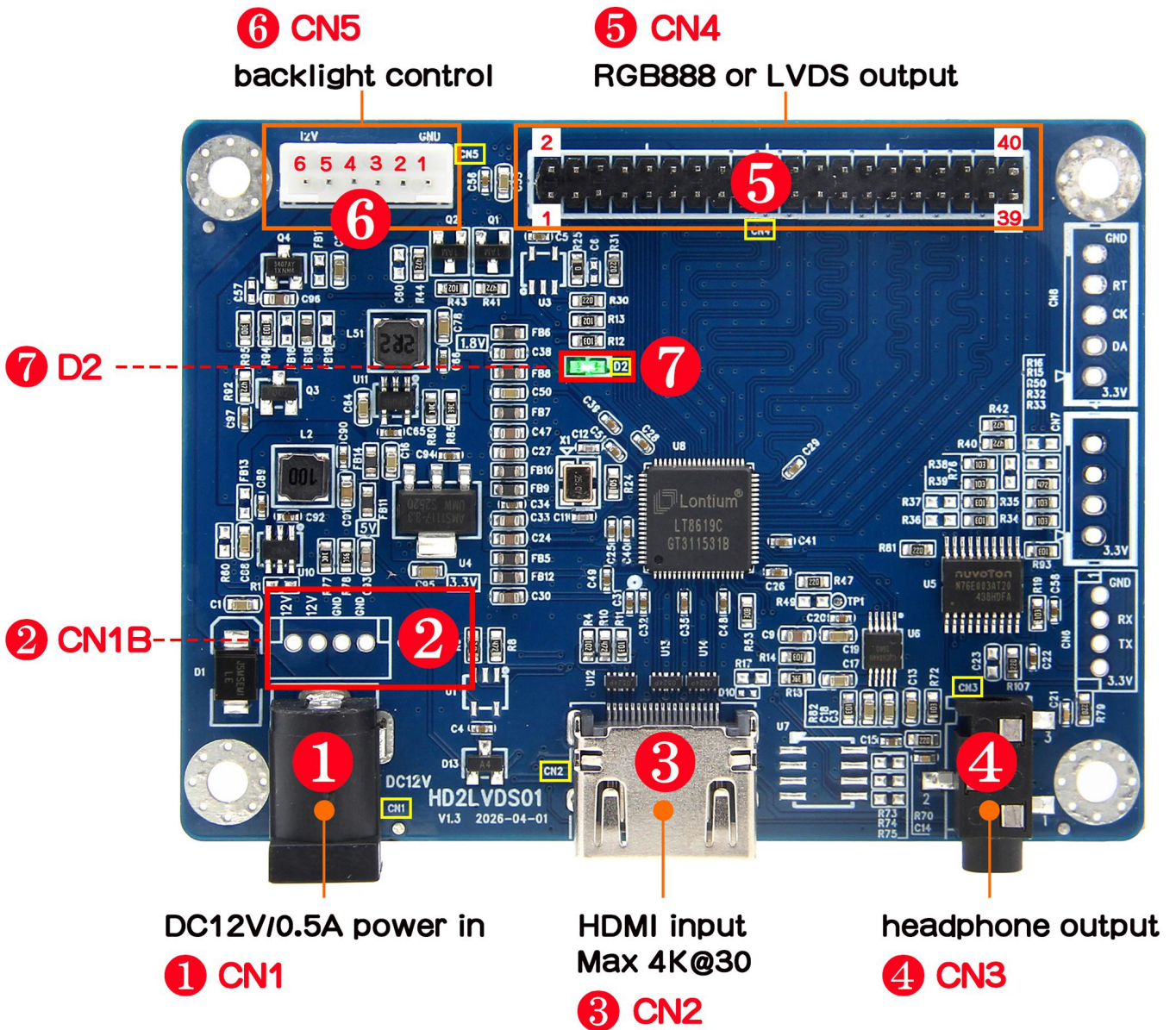

Figure 2: Interfaces

1. CN1: DC12V 5521 Power Input;
2. CN1B: PH2.0-4A, Backup DC12V input; Connected in parallel with CN1, to be used when using the built-in power supply.

Pin No.	Name	Description
1	+12V	Power supply
2	+12V	Power supply
3	GND	Grounding
4	GND	Grounding

3. CN2: HAMI A port 19P, HDMI input
4. CN3: 3.5mm stereo headphone jack, analog stereo output

5. CN4: 2.0mm 20*2 Dual Row Pin, RGB or LVDS Output

Pin No.	RGB888	1 Port LVDS	2Port LVDS	Pin No.	RGB888	1 Port LVDS	2Port LVDS
1	REFCLK	X	X	21	G2	LA2N	LA2N
2	VS	X	X	22	G3	LA2P	LA2P
3	DE	X	X	23	GND	GND	GND
4	HS	X	X	24	GND	GND	GND
5	B0	X	X	25	G4	LACN	LACN
6	B1	X	X	26	G5	LACP	LACP
7	B2	X	X	27	G6	LA3N	LA3N
8	B3	X	X	28	G7	LA3P	LA3P
9	B4	X	X	29	R0	X	LB0N
10	B5	X	X	30	R1	X	LB0P
11	+5V	+5V	+5V	31	R2	X	LB1N
12	+5V	+5V	+5V	32	R3	X	LB1P
13	+5V	+5V	+5V	33	R4	X	LB2N
14	GND	GND	GND	34	R5	X	LB2P
15	GND	GND	GND	35	GND	GND	GND
16	GND	GND	GND	36	GND	GND	GND
17	B6	LA0N	LA0N	37	R6	X	LBCN
18	B7	LA0P	LA0P	38	R7	X	LBCP
19	G0	LA1N	LA1N	39	X	X	LB3N
20	G1	LA1P	LA1P	40	X	X	LB3P

Note: "X" indicates that the pin signal is unavailable in the corresponding mode.

6. CN5: PH2.0-6A, backlight control, used for connecting to boost board when LVDS screen is on.

Pin No.	Name	Description
1	GND	Boost board power supply
2	GND	Boost board power supply
3	BL_ADJ	Backlight switch
4	BL_EN	Brightness adjustment
5	+12V	Grounding
6	+12V	Grounding

7. D2: Power LED, glows green when the board is powered on.

Input and output options:

(Output mode can be selected by shorting resistors on the board or via serial port settings. Once software settings are applied, the R36 and R37 options on the board become ineffective.)

1. Select output mode by shorting the resistor on board:

- a) **Default** : Leave R36 & R37 unsoldered - 2 Port LVDS output mode;
- b) Leave R37 unsoldered, solder 0Ω resistor to R36 - 1 Port LVDS output mode;
- c) Solder 0Ω resistor to R37 - RGB888 output mode

(R37 switches between LVDS and RGB888 mode. If R37 is unsoldered, R36 controls 1-port or 2-port output.)

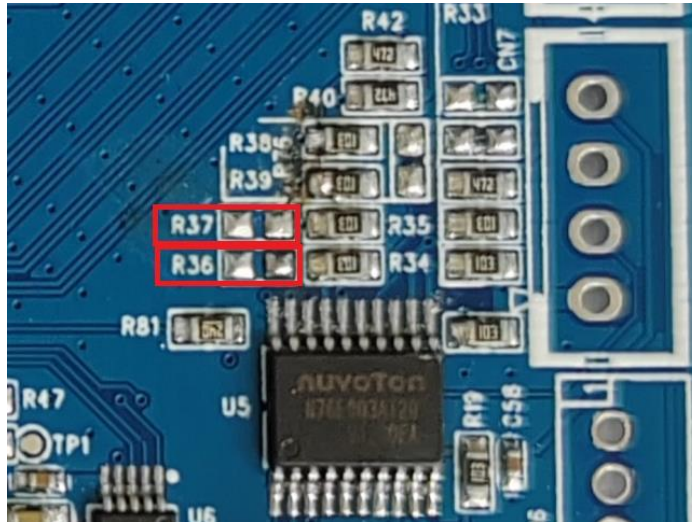

Figure 3: Hardware options

2. Select output mode via serial port:

- a) Connect the **CN6** on the board to the computer with a USB to UART cable (commonly used CH340G).

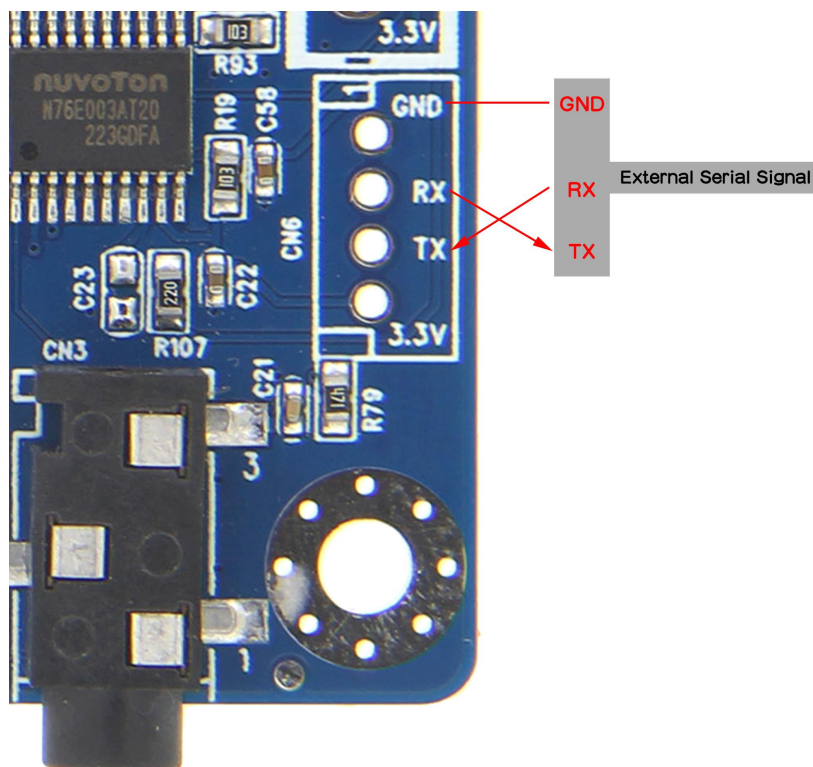

Figure 4: Serial port connection

b) Setting the serial port assistant, baud rate 115200

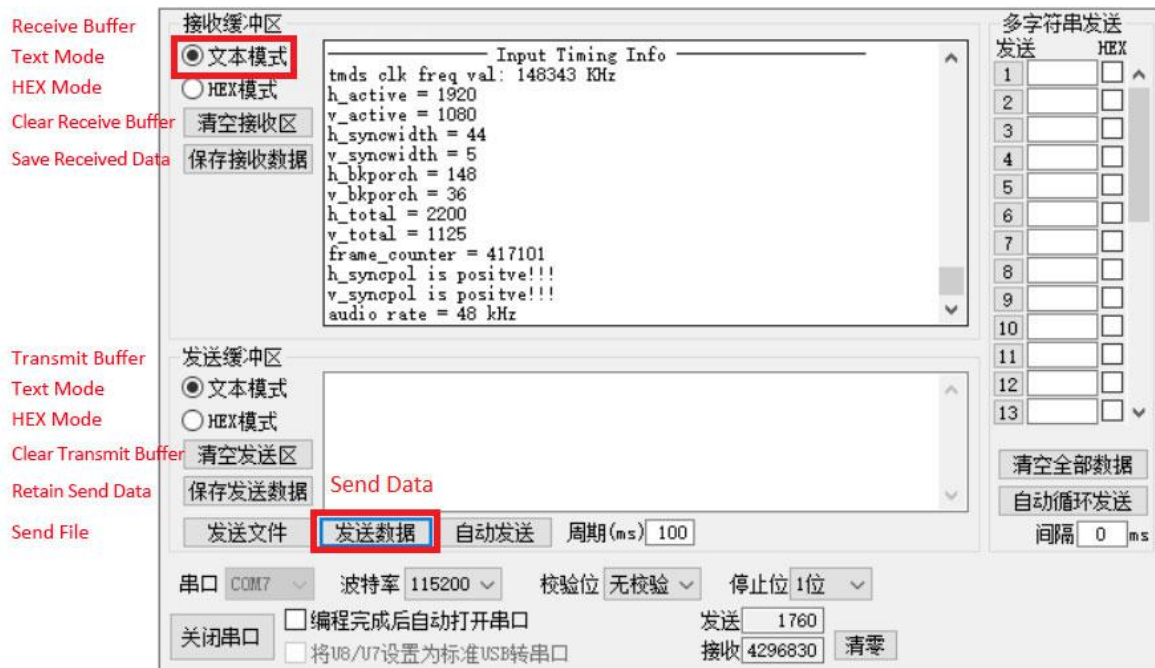

Figure 5: Serial port settings

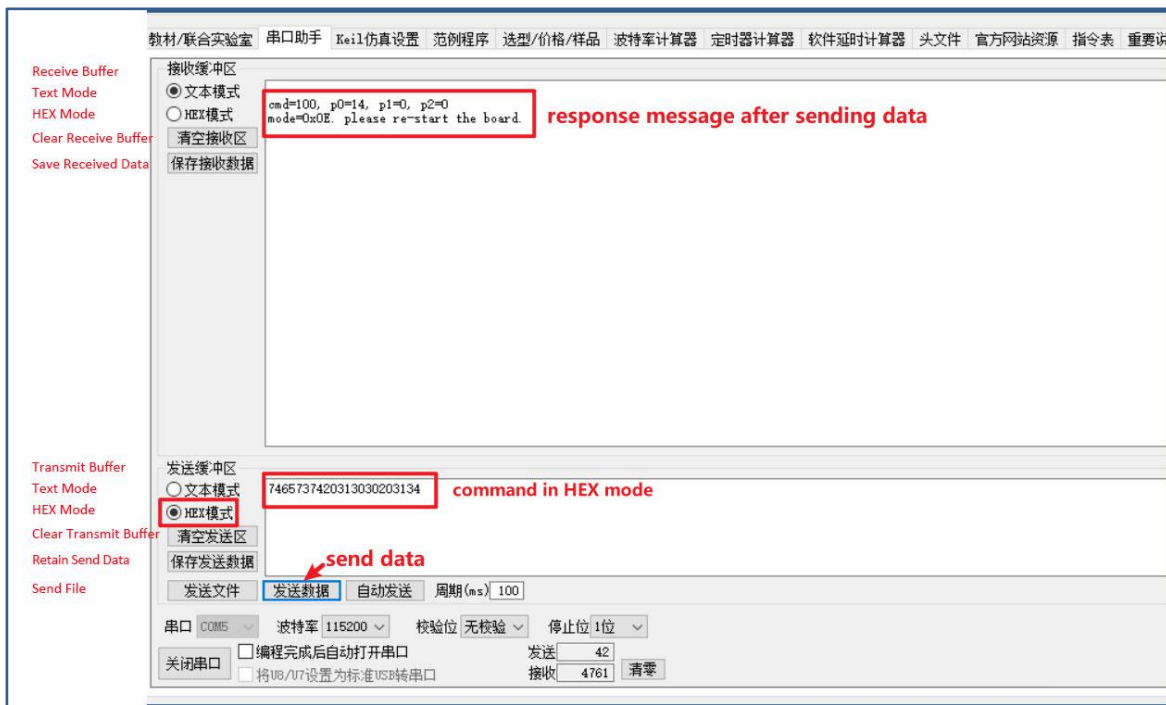

Figure 6: Hexadecimal commands

c) Output Mode Command

Input: **test 100 mode**

Click "Send Data". The command is successful if the receive window displays the following. Reboot the board afterward:

cmd=100, p0=0, p1=0, p2=0

mode=0x00, please re-start the board

Note: Parameter "mode" only accepts values 0~14 or 255.

0 = RGB888 output

13 = 2 Port LVDS output

14 = 1 Port LVDS output

Once software settings are applied, the R36 and R37 options on the board become ineffective. To revert to R36/R37 for output selection, enter the command: **test 100 255**

Note: Commands must be sent in ASCII encoding and must be in lowercase letters only; uppercase letters are not allowed.

d) HDMI Built-in EDID Preferred Resolution Modification Command

Input: **test 101 id**

Click "Send Data". The command is successful if the receive window displays the following. Reboot the board afterward:

cmd=101, p0=3, p1=0, p2=0

timing id=0x03, please re-start the board

Note: Parameter "id" only accepts values 0~18 or 255.

0:800*600/60Hz

1:1024*768/60Hz

2:1280*720/60Hz

3:1280*768/60Hz

4:1280*800/60Hz

5:1280*1024/60Hz

6:1360*768/60Hz

7:1440*900/60Hz

8:1600*1200/60Hz

9:1680*1050/60Hz

10:1920*1080/60Hz (Board's Default Resolution)

11:1920*1200/60Hz

12:3840*2160/30Hz

13:1920*720/60Hz

14:3840*720/60Hz

15:2560*1440/60Hz

16:1280*480/60Hz

17:1920*1080/120Hz

18:1360*768/60Hz-shrink

e) Backlight Brightness Adjustment Command

Input: **test 102 value**

Click "Send Data". The command is successful if the receive window displays the following – backlight brightness takes effect immediately:

cmd=102, p0=80, p1=0, p2=0

brightness=80

Note: Parameter "value" only accepts values 0~100. Brightness adjustment works solely with a connected boost board, using PWM dimming. The board's default brightness is 90.

f) LVDS 6bit/8bit Output Mode Setting Command

Input: **test 103 id**

Click "Send Data". The command is successful if the receive window displays the following. Reboot the board afterward:

cmd=103, p0=0, p1=0, p2=0

bit mode id=0x00, please re-start the board.

Note: Parameter "id" only accepts values 0 or 255.

0 = LVDS 6bit mode

255 = LVDS 8bit mode

The default LVDS output mode is 8bit.

g) LVDS Mapping Format (JEIDA/VESA) Setting Command

Input: **test 104 id**

Click "Send Data". The command is successful if the receive window displays the following. Reboot the board afterward:

cmd=104, p0=0, p1=0, p2=0

mapping mode id=0x00, please re-start the board.

Note: Parameter "id" only accepts values 0 or 255.

0 = JEIDA LVDS mapping format

255 = VESA LVDS mapping format

The default LVDS mapping format is VESA. If LVDS output is in 6bit mode, JEIDA and VESA mapping formats are identical.

3. Screen Power Selection via Dual-Row Pin Header

Pins 11, 12, 13 of dual-row pin header CN4 on the board supply screen power, **with a default output of 5V**. It can be switched to 12V by reworking the bead on the board, or to 3.3V via a jumper wire (see Figures 7 and 8).

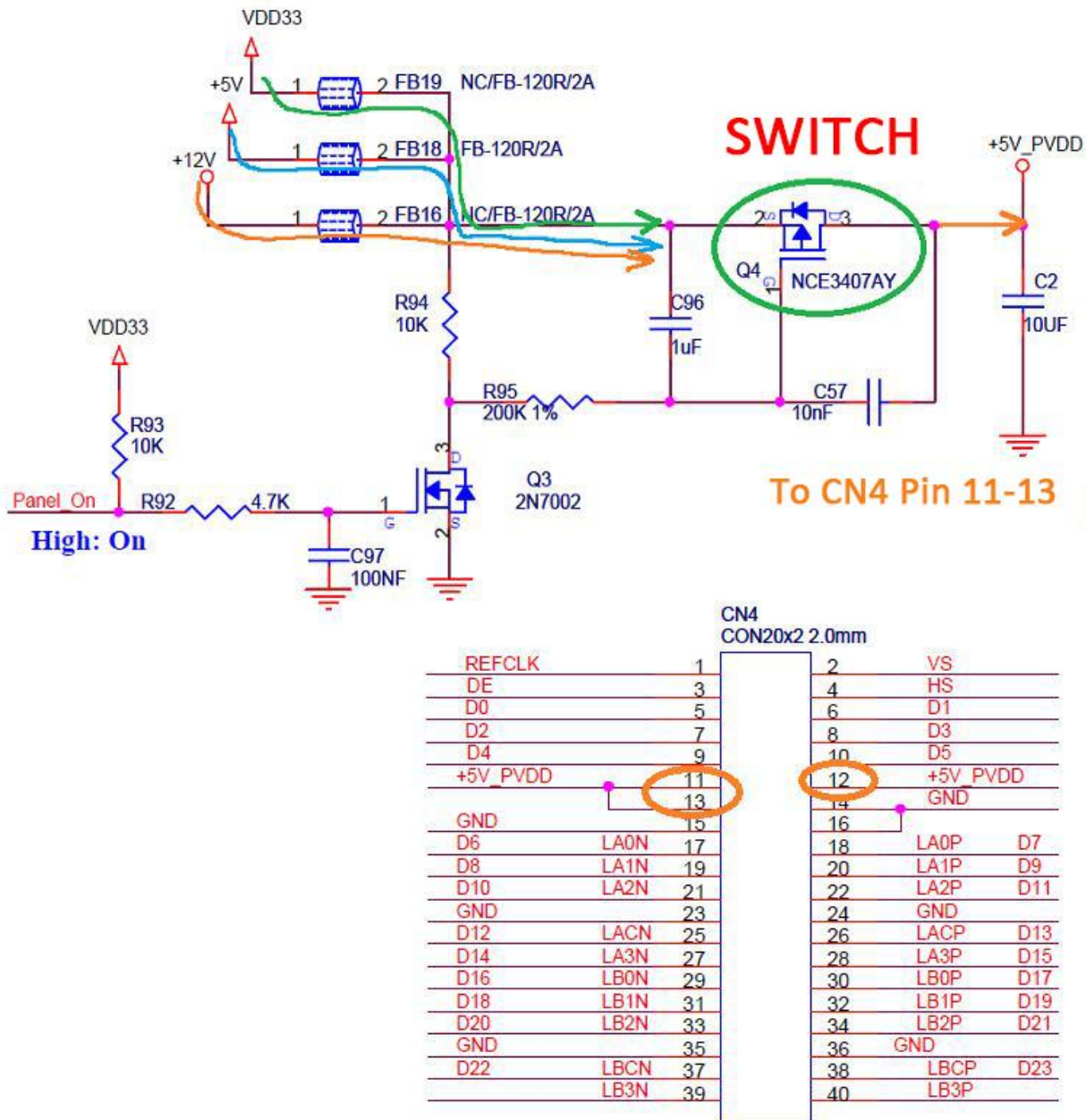

Figure 7: Screen Power Output

Only solder one among FB16, FB18 and FB19

- 1** Solder **FB16**: PVDD outputs 12V
- 2** Solder **FB18**: PVDD outputs 5V (Default)
- 3** Solder **FB19**: PVDD outputs 3.3V

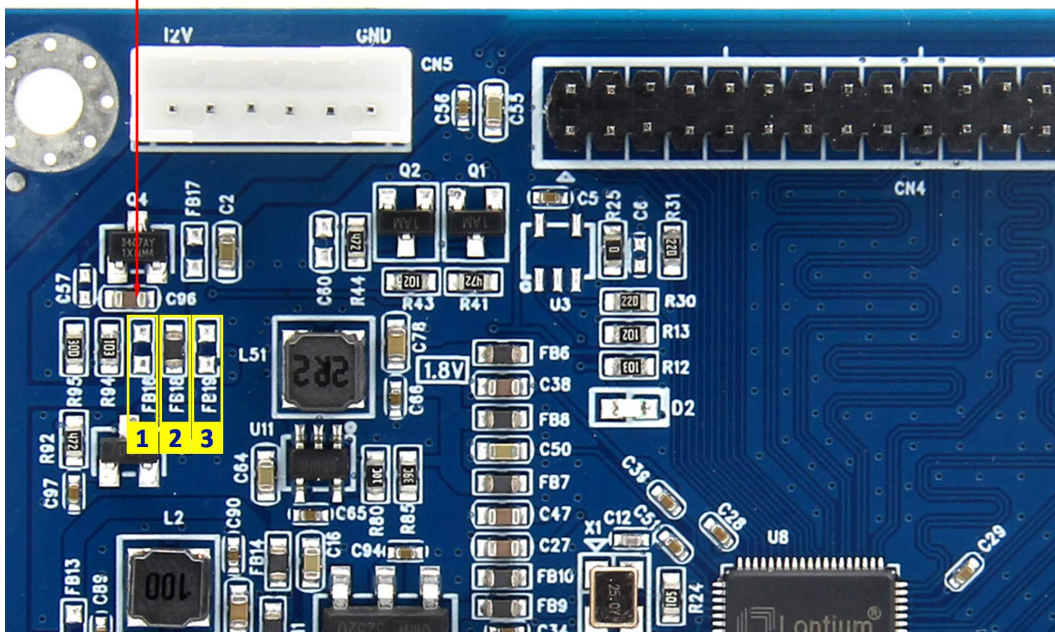

Figure 8: Screen Power Modification

Dimensions:

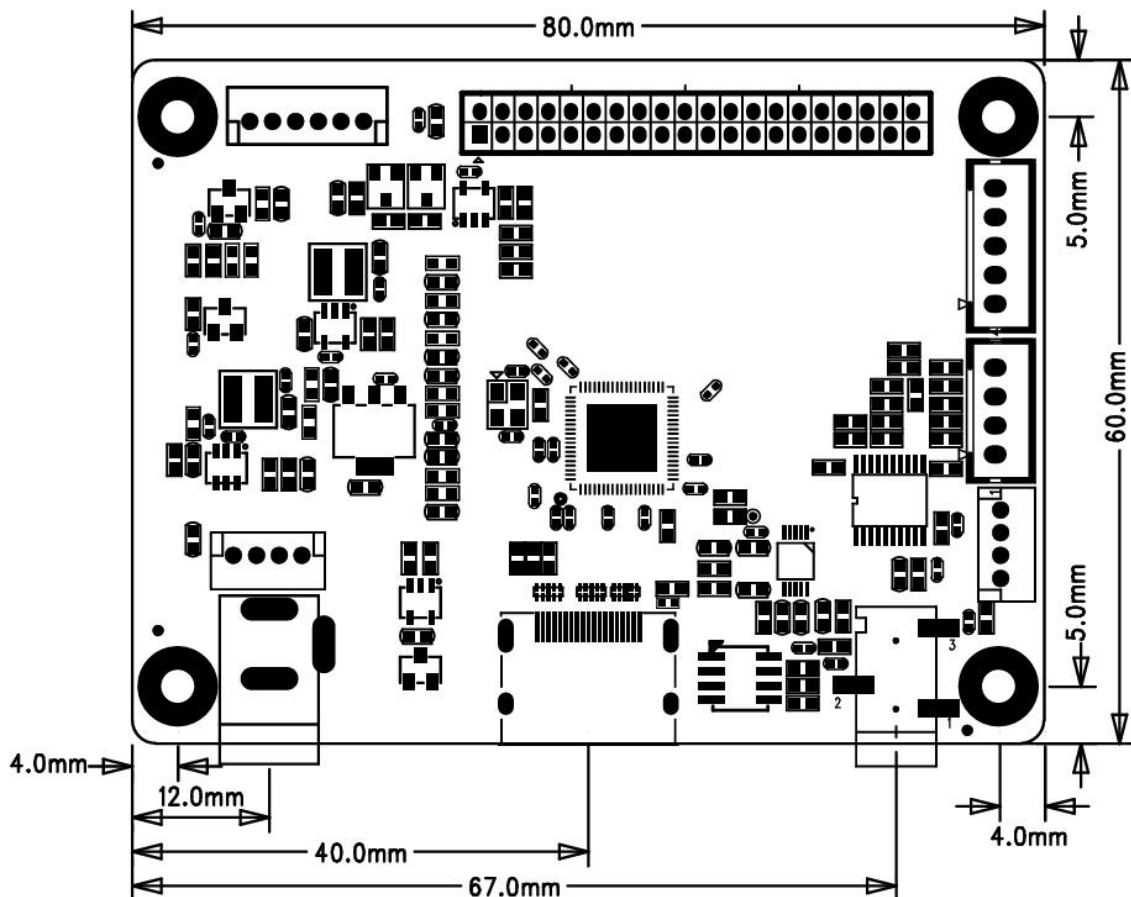

Figure 9: Mounting Dimensions

Debugging Notes

1. For RGB output, standard electronic connecting cables may cause TTL clock disturbance. When the clock frequency exceeds 80MHz, such cables can lead to image streaking and instability.
2. For LVDS output (screen driving), the solution uses point-to-point output without scaling. The HDMI signal resolution must match the screen parameters; otherwise, no image will be displayed.
3. For HDMI signals from a computer graphics card: Modify the EDID data to make the computer output the required resolution (define the EDID resolution with the same parameters as the LCD screen).
4. For non-computer signals (e.g., Android boards): Simply force the Android board to output an HDMI signal matching the screen parameters.

Connection example:

1. HDMI to RGB, then connect to RGB to HDMI output

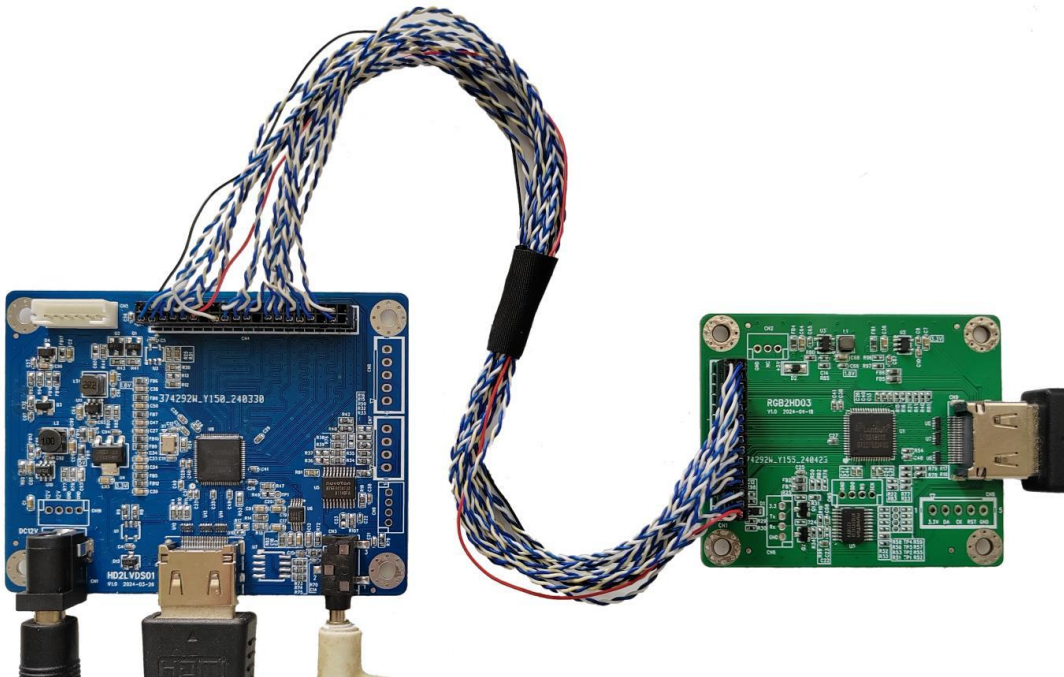

Figure10: Connection method 1

2. HDMI to LVDS to light up the screen

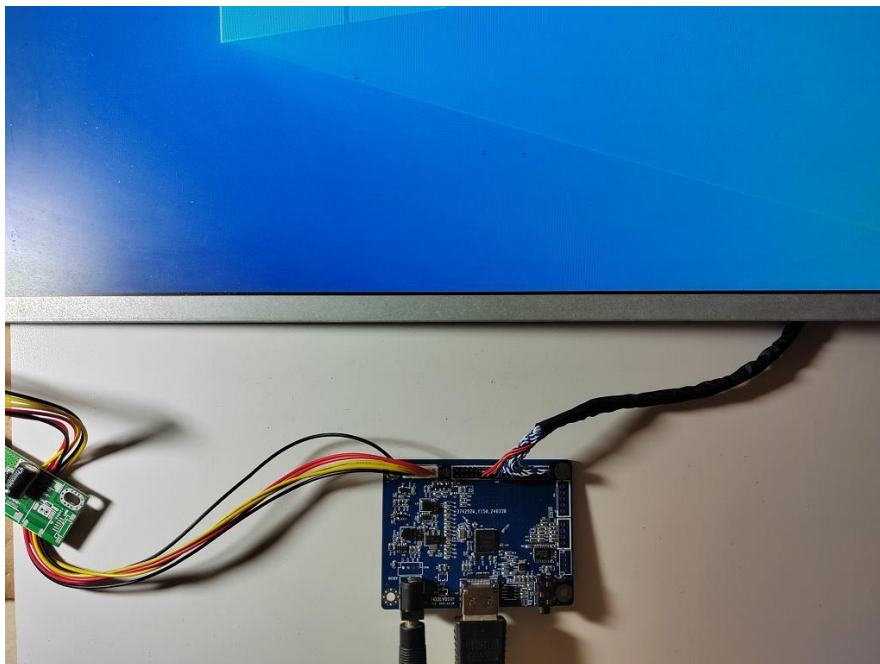

Figure 11: Connection method 2

3. HDMI to LVDS, then connect to LVDS to HDMI output

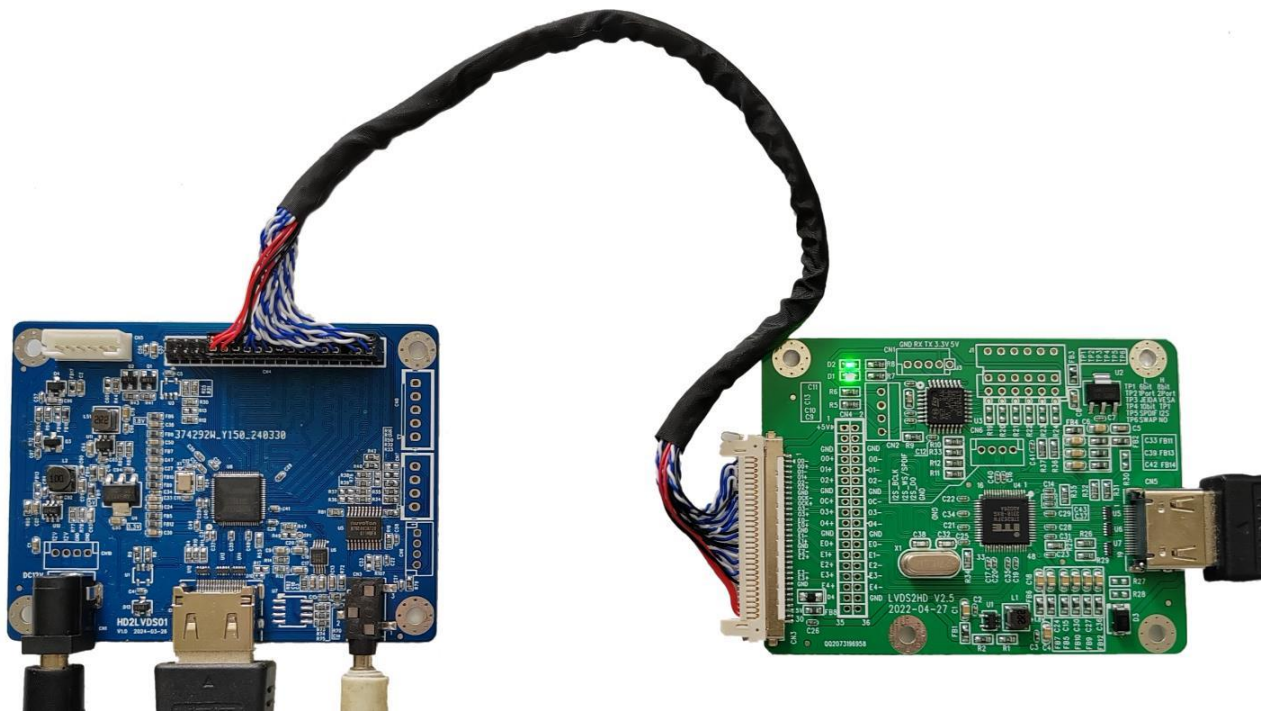

Figure 12: Connection method 3