

# ESP32-WROVER Datasheet



**Espressif Systems**

September 8, 2017

# About This Guide

This document provides the specifications for the ESP32-WROVER module.

The document structure is as follows:

Chapter	Title	Subject
Chapter 1	Preface	An overview of ESP32-WROVER
Chapter 2	Pin Definitions	Device pinout and pin descriptions
Chapter 3	Functional Description	Description of major functional modules
Chapter 4	Peripherals and Sensors	Description of peripherals.
Chapter 5	Electrical Characteristics	Electrical characteristics and specifications of ESP32-WROVER
Chapter 6	Schematics	The schematics of ESP32-WROVER
Chapter 7	Peripheral Schematics	The peripheral schematics of ESP32-WROVER
Chapter 8	Dimensions	The dimensions of ESP32-WROVER
Chapter 8	Learning Resources	ESP32-related must-read materials and must-have resources

## Release Notes

Date	Version	Release notes
2017.08	V1.0	First release
2017.09	V1.1	Updated Section 2.1 Pin Layout; Updated the ESP32-WROVER Schematics and added a note in Chapter 7; Added Chapter 8 Dimensions.

## Documentation Change Notification

Espressif provides email notifications to keep customers updated on changes to technical documentation. Please subscribe [here](#).

## Certificates

Download certificates for Espressif products from [here](#).

## Disclaimer and Copyright Notice

Information in this document, including URL references, is subject to change without notice. THIS DOCUMENT IS PROVIDED AS IS WITH NO WARRANTIES WHATSOEVER, INCLUDING ANY WARRANTY OF MERCHANTABILITY, NON-INFRINGEMENT, FITNESS FOR ANY PARTICULAR PURPOSE, OR ANY WARRANTY OTHERWISE ARISING OUT OF ANY PROPOSAL, SPECIFICATION OR SAMPLE.

All liability, including liability for infringement of any proprietary rights, relating to use of information in this document is disclaimed. No licenses express or implied, by estoppel or otherwise, to any intellectual property rights are granted herein. The Wi-Fi Alliance Member logo is a trademark of the Wi-Fi Alliance. The Bluetooth logo is a registered trademark of Bluetooth SIG.

All trade names, trademarks and registered trademarks mentioned in this document are property of their respective owners, and are hereby acknowledged.

**Copyright © 2017 Espressif Inc. All rights reserved.**

# Contents

<b>1 Overview</b>	1
<b>2 Pin Definitions</b>	3
2.1 Pin Layout	3
2.2 Pin Description	4
2.3 Strapping Pins	5
<b>3 Functional Description</b>	7
3.1 CPU and Internal Memory	7
3.2 External Flash and SRAM	7
3.3 Crystal Oscillators	7
3.4 RTC and Low-Power Management	8
<b>4 Peripherals and Sensors</b>	10
4.1 Peripherals and Sensors Description	10
<b>5 Electrical Characteristics</b>	15
5.1 Absolute Maximum Ratings	15
5.2 Wi-Fi Radio	15
5.3 BLE Radio	16
5.3.1 Receiver	16
5.3.2 Transmitter	16
5.4 Reflow Profile	17
<b>6 Schematics</b>	18
<b>7 Peripheral Schematics</b>	19
<b>8 Dimensions</b>	20
<b>9 Learning Resources</b>	21
9.1 Must-Read Documents	21
9.2 Must-Have Resources	21

## List of Tables

1	ESP32-WROVER Specifications	1
2	Pin Definitions	4
3	Strapping Pins	5
4	Functionalities Depending on the Power Modes	8
5	Power Consumption by Power Modes	8
6	Description of Peripherals and Sensors	10
7	Absolute Maximum Ratings	15
8	Wi-Fi Radio Characteristics	15
9	Receiver Characteristics — BLE	16
10	Transmitter Characteristics — BLE	16

## List of Figures

1	ESP32-WROVER Pin Layout	3
2	Reflow Profile	17
3	ESP32-WROVER Schematics	18
4	ESP32-WROVER Peripheral Schematics	19
5	ESP32-WROVER Dimensions	20

# 1. Overview

ESP32-WROVER is a powerful, generic WiFi-BT-BLE MCU module that targets a wide variety of applications, ranging from low-power sensor networks to the most demanding tasks, such as voice encoding, music streaming and MP3 decoding.

At the core of this module is the ESP32-D0WDQ6 chip\*, same as ESP-WROOM-32 module. Compared to ESP-WROOM-32, ESP32-WROVER has an additional SPI Pseudo static RAM (PSRAM) of 32 Mbits. As such, ESP32-WROVER features both 4 MB external SPI flash and 4 MB external PSRAM.

The ESP32-WROVER module has a PCB antenna, while the ESP32-WROVER-I uses an IPEX antenna. The information in this datasheet is applicable to both of the two modules.

The chip embedded is designed to be scalable and adaptive. There are two CPU cores that can be individually controlled, and the clock frequency is adjustable from 80 MHz to 240 MHz. The user may also power off the CPU and make use of the low-power co-processor to constantly monitor the peripherals for changes or crossing of thresholds. ESP32 integrates a rich set of peripherals, ranging from capacitive touch sensors, Hall sensors, low-noise sense amplifiers, SD card interface, Ethernet, high-speed SPI, UART, I2S and I2C.

**Note:**

\* For details on the part number of the ESP32 series, please refer to the document [ESP32 Datasheet](#).

The integration of Bluetooth, Bluetooth LE and Wi-Fi ensures that a wide range of applications can be targeted, and that the module is future proof: using Wi-Fi allows a large physical range and direct connection to the internet through a Wi-Fi router, while using Bluetooth allows the user to conveniently connect to the phone or broadcast low energy beacons for its detection. The sleep current of the ESP32 chip is less than 5  $\mu$ A, making it suitable for battery powered and wearable electronics applications. ESP32 supports a data rate of up to 150 Mbps, and 20.5 dBm output power at the antenna to ensure the widest physical range. As such the chip does offer industry-leading specifications and the best performance for electronic integration, range, power consumption, and connectivity.

The operating system chosen for ESP32 is freeRTOS with LwIP; TLS 1.2 with hardware acceleration is built in as well. Secure (encrypted) over the air (OTA) upgrade is also supported, so that developers can continually upgrade their products even after their release.

Table 1 provides the specifications of ESP32-WROVER.

**Table 1: ESP32-WROVER Specifications**

Categories	Items	Specifications
Wi-Fi	RF certification	FCC/CE-RED/SRRC
	Protocols	802.11 b/g/n/e/i (802.11n up to 150 Mbps)
		A-MPDU and A-MSDU aggregation and 0.4 $\mu$ s guard interval support
Frequency range	2.4 GHz ~ 2.5 GHz	

Categories	Items	Specifications
Bluetooth	Protocols	Bluetooth v4.2 BR/EDR and BLE specification
	Radio	NZIF receiver with -97 dBm sensitivity
		Class-1, class-2 and class-3 transmitter
		AFH
Audio	CVSD and SBC	
Hardware	Module interface	SD card, UART, SPI, SDIO, I2C, LED PWM, Motor PWM, I2S, IR
		GPIO, capacitive touch sensor, ADC, DAC, LNA pre-amplifier
	On-chip sensor	Hall sensor, temperature sensor
	On-board clock	40 MHz crystal
	Operating voltage/Power supply	2.3 ~ 3.6V
	Operating current	Average: 80 mA
	Minimum current delivered by power supply	500 mA
	Operating temperature range	-40°C ~ 85°C
	Ambient temperature range	Normal temperature
	Package size	18±0.2 mm x 31.4±0.2 mm x 3.3±0.15 mm
Software	Wi-Fi mode	Station/SoftAP/SoftAP+Station/P2P
	Security	WPA/WPA2/WPA2-Enterprise/WPS
	Encryption	AES/RSA/ECC/SHA
	Firmware upgrade	UART Download / OTA (via network) / download and write firmware via host
	Software development	Supports Cloud Server Development / SDK for custom firmware development
	Network protocols	IPv4, IPv6, SSL, TCP/UDP/HTTP/FTP/MQTT
	User configuration	AT instruction set, cloud server, Android/iOS app

## 2. Pin Definitions

### 2.1 Pin Layout

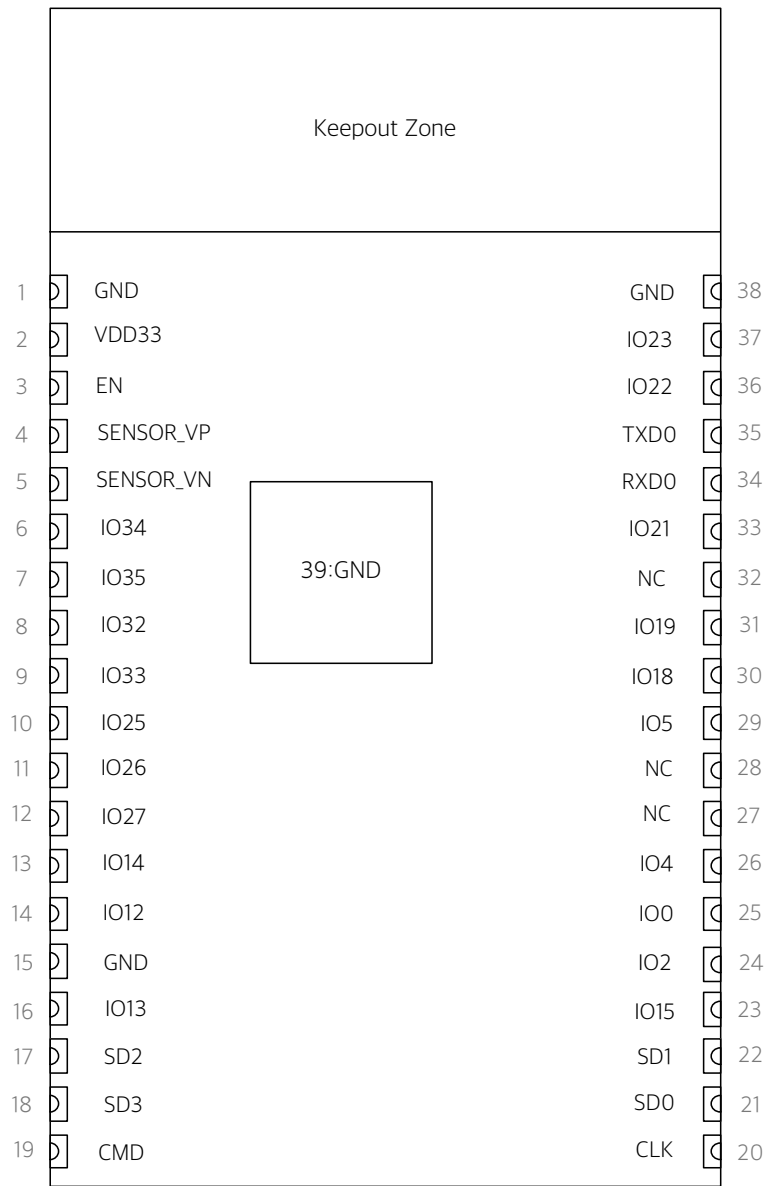

Figure 1: ESP32-WROVER Pin Layout



## 2.2 Pin Description

ESP32-WROVER has 38 pins. See pin definitions in Table 2.

**Table 2: Pin Definitions**

Name	No.	Type	Function
GND	1	P	Ground
3V3	2	P	Power supply.
EN	3	I	Chip-enable signal. Active high.
SENSOR_VP	4	I	GPIO36, SENSOR_VP, ADC_H, ADC1_CH0, RTC_GPIO0
SENSOR_VN	5	I	GPIO39, SENSOR_VN, ADC1_CH3, ADC_H, RTC_GPIO3
IO34	6	I	GPIO34, ADC1_CH6, RTC_GPIO4
IO35	7	I	GPIO35, ADC1_CH7, RTC_GPIO5
IO32	8	I/O	GPIO32, XTAL_32K_P (32.768 kHz crystal oscillator input), ADC1_CH4, TOUCH9, RTC_GPIO9
IO33	9	I/O	GPIO33, XTAL_32K_N (32.768 kHz crystal oscillator output), ADC1_CH5, TOUCH8, RTC_GPIO8
IO25	10	I/O	GPIO25, DAC_1, ADC2_CH8, RTC_GPIO6, EMAC_RXD0
IO26	11	I/O	GPIO26, DAC_2, ADC2_CH9, RTC_GPIO7, EMAC_RXD1
IO27	12	I/O	GPIO27, ADC2_CH7, TOUCH7, RTC_GPIO17, EMAC_RX_DV
IO14	13	I/O	GPIO14, ADC2_CH6, TOUCH6, RTC_GPIO16, MTMS, HSPICLK, HS2_CLK, SD_CLK, EMAC_TXD2
IO12	14	I/O	GPIO12, ADC2_CH5, TOUCH5, RTC_GPIO15, MTDI, HSPIQ, HS2_DATA2, SD_DATA2, EMAC_TXD3
GND	15	P	Ground
IO13	16	I/O	GPIO13, ADC2_CH4, TOUCH4, RTC_GPIO14, MTCK, HSPID, HS2_DATA3, SD_DATA3, EMAC_RX_ER
SHD/SD2*	17	I/O	GPIO9, SD_DATA2, SPIHD, HS1_DATA2, U1RXD
SWP/SD3*	18	I/O	GPIO10, SD_DATA3, SPIWP, HS1_DATA3, U1TXD
SCS/CMD*	19	I/O	GPIO11, SD_CMD, SPICS0, HS1_CMD, U1RTS
SCK/CLK*	20	I/O	GPIO6, SD_CLK, SPICLK, HS1_CLK, U1CTS
SDO/SD0*	21	I/O	GPIO7, SD_DATA0, SPIQ, HS1_DATA0, U2RTS
SDI/SD1*	22	I/O	GPIO8, SD_DATA1, SPID, HS1_DATA1, U2CTS
IO15	23	I/O	GPIO15, ADC2_CH3, TOUCH3, MTDO, HSPICS0, RTC_GPIO13, HS2_CMD, SD_CMD, EMAC_RXD3
IO2	24	I/O	GPIO2, ADC2_CH2, TOUCH2, RTC_GPIO12, HSPiWP, HS2_DATA0, SD_DATA0
IO0	25	I/O	GPIO0, ADC2_CH1, TOUCH1, RTC_GPIO11, CLK_OUT1, EMAC_TX_CLK
IO4	26	I/O	GPIO4, ADC2_CH0, TOUCH0, RTC_GPIO10, HSPiHD, HS2_DATA1, SD_DATA1, EMAC_TX_ER
IO16	27	I/O	GPIO16, HS1_DATA4, U2RXD, EMAC_CLK_OUT
IO17	28	I/O	GPIO17, HS1_DATA5, U2TXD, EMAC_CLK_OUT_180
IO5	29	I/O	GPIO5, VSPICS0, HS1_DATA6, EMAC_RX_CLK
IO18	30	I/O	GPIO18, VSPICLK, HS1_DATA7
IO19	31	I/O	GPIO19, VSPIQ, U0CTS, EMAC_TXD0

Name	No.	Type	Function
NC	32	-	-
IO21	33	I/O	GPIO21, VSPIHD, EMAC_TX_EN
RXD0	34	I/O	GPIO3, U0RXD, CLK_OUT2
TXD0	35	I/O	GPIO1, U0TXD, CLK_OUT3, EMAC_RXD2
IO22	36	I/O	GPIO22, VSPIWP, U0RTS, EMAC_TXD1
IO23	37	I/O	GPIO23, VSPID, HS1_STROBE
GND	38	P	Ground

## 2.3 Strapping Pins

Please refer to Chapter 6 ESP32-WROVER schematics. ESP32 has five strapping pins, which can be seen in Section 6 Schematics:

- MTDI
- GPIO0
- GPIO2
- MTDO
- GPIO5

Software can read the value of these five bits from the register "GPIO\_STRAPPING".

During the chip power-on reset, the latches of the strapping pins sample the voltage level as strapping bits of "0" or "1", and hold these bits until the chip is powered down or shut down. The strapping bits configure the device boot mode, the operating voltage of VDD\_SDIO and other system initial settings.

Each strapping pin is connected with its internal pull-up/pull-down during the chip reset. Consequently, if a strapping pin is unconnected or the connected external circuit is high-impedance, the internal weak pull-up/pull-down will determine the default input level of the strapping pins.

To change the strapping bit values, users can apply the external pull-down/pull-up resistances, or apply the host MCU's GPIOs to control the voltage level of these pins when powering on ESP32.

After reset, the strapping pins work as the normal functions pins.

Refer to Table 3 for detailed boot modes' configuration by strapping pins.

**Table 3: Strapping Pins**

Voltage of Internal LDO (VDD_SDIO)			
Pin	Default	3.3V	1.8V
MTDI	Pull-down	0	1
Bootling Mode			
Pin	Default	SPI Boot	Download Boot
GPIO0	Pull-up	1	0
GPIO2	Pull-down	Don't-care	0
Debugging Log on U0TXD During Bootling			
Pin	Default	U0TXD Toggling	U0TXD Silent
MTDO	Pull-up	1	0

Timing of SDIO Slave						
Pin	Default	Falling-edge Input Falling-edge Output	Falling-edge Input Rising-edge Output	Rising-edge Input Falling-edge Output	Rising-edge Input Rising-edge Output	
MTDO	Pull-up	0	0	1	1	
GPIO5	Pull-up	0	1	0	1	

**Note:**

- Firmware can configure register bits to change the settings of "Voltage of Internal LDO (VDD\_SDIO)" and "Timing of SDIO Slave" after booting.
- The MTDI is internally pulled high in the module, as the flash and SRAM in ESP32-WROVER only support a power voltage of 1.8V (output by VDD\_SDIO).

## 3. Functional Description

This chapter describes the modules and functions integrated in ESP32-WROVER.

### 3.1 CPU and Internal Memory

ESP32-D0WDQ6 contains two low-power Xtensa® 32-bit LX6 microprocessors. The internal memory includes:

- 448 KB of ROM for booting and core functions.
- 520 KB (8 KB RTC FAST Memory included) of on-chip SRAM for data and instruction.
  - 8 KB of SRAM in RTC, which is called RTC FAST Memory and can be used for data storage; it is accessed by the main CPU during RTC Boot from the Deep-sleep mode.
- 8 KB of SRAM in RTC, which is called RTC SLOW Memory and can be accessed by the co-processor during the Deep-sleep mode.
- 1 kbit of eFuse, of which 256 bits are used for the system (MAC address and chip configuration) and the remaining 768 bits are reserved for customer applications, including Flash-Encryption and Chip-ID.

### 3.2 External Flash and SRAM

ESP32 supports up to four 16-MB of external QSPI flash and SRAM with hardware encryption based on AES to protect developers' programs and data.

ESP32 can access the external QSPI flash and SRAM through high-speed caches.

- Up to 16 MB of external flash are memory-mapped onto the CPU code space, supporting 8, 16 and 32-bit access. Code execution is supported.
- Up to 8 MB of external flash/SRAM are memory-mapped onto the CPU data space, supporting 8, 16 and 32-bit access. Data-read is supported on the flash and SRAM. Data-write is supported on the SRAM.

ESP32-WROVER integrates 4 MB of external SPI flash. The 4-MB SPI flash can be memory-mapped onto the CPU code space, supporting 8, 16 and 32-bit access. Code execution is supported.

In addition to the 4 MB SPI flash, ESP32-WROVER also integrates 4 MB PSRAM for more memory space.

### 3.3 Crystal Oscillators

The ESP32 Wi-Fi/BT firmware can only support 40 MHz crystal oscillator for now.

### 3.4 RTC and Low-Power Management

With the use of advanced power management technologies, ESP32 can switch between different power modes (see Table 4).

- Power modes
  - Active mode: The chip radio is powered on. The chip can receive, transmit, or listen.
  - Modem-sleep mode: The CPU is operational and the clock is configurable. The Wi-Fi/Bluetooth baseband and radio are disabled.
  - Light-sleep mode: The CPU is paused. The RTC memory and RTC peripherals, as well as the ULP co-processor are running. Any wake-up events (MAC, host, RTC timer, or external interrupts) will wake up the chip.
  - Deep-sleep mode: Only the RTC memory and RTC peripherals are powered on. Wi-Fi and Bluetooth connection data are stored in the RTC memory. The ULP co-processor can work.
  - Hibernation mode: The internal 8-MHz oscillator and ULP co-processor are disabled. The RTC recovery memory is powered down. Only one RTC timer on the slow clock and some RTC GPIOs are active. The RTC timer or the RTC GPIOs can wake up the chip from the Hibernation mode.
- Sleep Patterns
  - Association sleep pattern: The power mode switches between the Active mode, Modem- and Light-sleep mode during this sleep pattern. The CPU, Wi-Fi, Bluetooth, and radio are woken up at predetermined intervals to keep Wi-Fi/BT connections alive.
  - ULP sensor-monitored pattern: The main CPU is in the Deep-sleep mode. The ULP co-processor takes sensor measurements and wakes up the main system, based on the data collected from sensors.

**Table 4: Functionalities Depending on the Power Modes**

Power mode	Active	Modem-sleep	Light-sleep	Deep-sleep	Hibernation
Sleep pattern	Association sleep pattern			ULP sensor-monitored pattern	-
CPU	ON	ON	PAUSE	OFF	OFF
Wi-Fi/BT baseband and radio	ON	OFF	OFF	OFF	OFF
RTC memory and RTC peripherals	ON	ON	ON	ON	OFF
ULP co-processor	ON	ON	ON	ON/OFF	OFF

The power consumption varies with different power modes/sleep patterns and work statuses of functional modules. Please see Table 5 for details.

**Table 5: Power Consumption by Power Modes**

Power mode	Description	Power consumption
Active (RF working)	Wi-Fi Tx packet 14 dBm ~ 19.5 dBm	Please refer to <a href="#">ESP32 Datasheet</a> .
	Wi-Fi / BT Tx packet 0 dBm	
	Wi-Fi / BT Rx and listening	
	Association sleep pattern (by Light-sleep)	1 mA ~ 4 mA @DTIM3

Power mode	Description	Power consumption
Modem-sleep	The CPU is powered on.	Max speed 240 MHz: 30 mA ~ 50 mA
		Normal speed 80 MHz: 20 mA ~ 25 mA
		Slow speed 2 MHz: 2 mA ~ 4 mA
Light-sleep	-	0.8 mA
Deep-sleep	The ULP co-processor is powered on.	150 $\mu$ A
	ULP sensor-monitored pattern	100 $\mu$ A @1% duty
	RTC timer + RTC memory	10 $\mu$ A
Hibernation	RTC timer only	5 $\mu$ A
Power off	CHIP_PU is set to low level, the chip is powered off	0.1 $\mu$ A

**Note:**

- During Deep-sleep, when the ULP co-processor is powered on, peripherals such as GPIO and I2C are able to work.
- When the system works in the ULP sensor-monitored pattern, the ULP co-processor works with the ULP sensor periodically; ADC works with a duty cycle of 1%, so the power consumption is 100  $\mu$ A.

## 4. Peripherals and Sensors

### 4.1 Peripherals and Sensors Description

**Table 6: Description of Peripherals and Sensors**

Interface	Signal	Pin	Function
ADC	ADC1_CH0	SENSOR_VP	Two 12-bit SAR ADCs
	ADC1_CH3	SENSOR_VN	
	ADC1_CH4	IO32	
	ADC1_CH5	IO33	
	ADC1_CH6	IO34	
	ADC1_CH7	IO35	
	ADC2_CH0	IO4	
	ADC2_CH1	IO0	
	ADC2_CH2	IO2	
	ADC2_CH3	IO15	
	ADC2_CH4	IO13	
	ADC2_CH5	IO12	
	ADC2_CH6	IO14	
	ADC2_CH7	IO27	
	ADC2_CH8	IO25	
ADC2_CH9	IO26		
Ultra-Low Noise Analog Pre-Amplifier	SENSOR_VP	IO36	Provides about 60 dB gain by using larger capacitors on PCB
	SENSOR_VN	IO39	
DAC	DAC_1	IO25	Two 8-bit DACs
	DAC_2	IO26	
Touch Sensor	TOUCH0	IO4	Capacitive touch sensors
	TOUCH1	IO0	
	TOUCH2	IO2	
	TOUCH3	IO15	
	TOUCH4	IO13	
	TOUCH5	IO12	
	TOUCH6	IO14	
	TOUCH7	IO27	
	TOUCH8	IO33	
	TOUCH9	IO32	
SD/SDIO/MMC Host Controller	HS2_CLK	MTMS	Supports SD memory card V3.01 standard
	HS2_CMD	MTDO	
	HS2_DATA0	IO2	
	HS2_DATA1	IO4	
	HS2_DATA2	MTDI	
	HS2_DATA3	MTCK	

Interface	Signal	Pin	Function
Motor PWM	PWM0_OUT0~2	Any GPIOs*	Three channels of 16-bit timers generate PWM waveforms. Each channel has a pair of output signals, three fault detection signals, three event-capture signals, and three sync signals.
	PWM1_OUT_IN0~2		
	PWM0_FLT_IN0~2		
	PWM1_FLT_IN0~2		
	PWM0_CAP_IN0~2		
	PWM1_CAP_IN0~2		
	PWM0_SYNC_IN0~2		
	PWM1_SYNC_IN0~2		
LED PWM	ledc_hs_sig_out0~7	Any GPIOs*	16 independent channels @80 MHz clock/RTC CLK. Duty accuracy: 16 bits.
	ledc_ls_sig_out0~7		
UART	U0RXD_in	Any GPIOs*	Two UART devices with hardware flow-control and DMA
	U0CTS_in		
	U0DSR_in		
	U0TXD_out		
	U0RTS_out		
	U0DTR_out		
	U1RXD_in		
	U1CTS_in		
	U1TXD_out		
	U1RTS_out		
	U2RXD_in		
	U2CTS_in		
	U2TXD_out		
	U2RTS_out		
I2C	I2CEXT0_SCL_in	Any GPIOs*	Two I2C devices in slave or master modes
	I2CEXT0_SDA_in		
	I2CEXT1_SCL_in		
	I2CEXT1_SDA_in		
	I2CEXT0_SCL_out		
	I2CEXT0_SDA_out		
	I2CEXT1_SCL_out		
	I2CEXT1_SDA_out		



Interface	Signal	Pin	Function
I2S	I2S0I_DATA_in0~15	Any GPIOs*	Stereo input and output from/to the audio codec, and parallel LCD data output
	I2S0O_BCK_in		
	I2S0O_WS_in		
	I2S0I_BCK_in		
	I2S0I_WS_in		
	I2S0I_H_SYNC		
	I2S0I_V_SYNC		
	I2S0I_H_ENABLE		
	I2S0O_BCK_out		
	I2S0O_WS_out		
	I2S0I_BCK_out		
	I2S0I_WS_out		
	I2S0O_DATA_out0~23		
	I2S1I_DATA_in0~15		
	I2S1O_BCK_in		
	I2S1O_WS_in		
	I2S1I_BCK_in		
	I2S1I_WS_in		
	I2S1I_H_SYNC		
	I2S1I_V_SYNC		
	I2S1I_H_ENABLE		
	I2S1O_BCK_out		
	I2S1O_WS_out		
I2S1I_BCK_out			
I2S1I_WS_out			
I2S1O_DATA_out0~23			
Remote Controller	RMT_SIG_IN0~7	Any GPIOs*	Eight channels of IR transmitter and receiver for various waveforms
	RMT_SIG_OUT0~7		

Interface	Signal	Pin	Function
Parallel QSPI	SPIHD	SHD/SD2	Supports Standard SPI, Dual SPI, and Quad SPI that can be connected to the external flash and SRAM
	SPIWP	SWP/SD3	
	SPICS0	SCS/CMD	
	SPICLK	SCK/CLK	
	SPIQ	SDO/SD0	
	SPID	SDI/SD1	
	HSPICLK	IO14	
	HSPICS0	IO15	
	HSPIQ	IO12	
	HSPID	IO13	
	HSPIHD	IO4	
	HSPIWP	IO2	
	VSPICLK	IO18	
	VSPICS0	IO5	
	VSPIQ	IO19	
	VSPID	IO23	
VSPIHD	IO21		
VSPIWP	IO22		
General Purpose SPI	HSPIQ_in/_out	Any GPIOs*	Standard SPI consists of clock, chip-select, MOSI and MISO. These SPIs can be connected to LCD and other external devices. They support the following features: <ul style="list-style-type: none"> <li>• both master and slave modes;</li> <li>• 4 sub-modes of the SPI format transfer that depend on the clock phase (CPHA) and clock polarity (CPOL) control;</li> <li>• configurable SPI frequency;</li> <li>• up to 64 bytes of FIFO and DMA.</li> </ul>
	HSPIQ_in/_out		
	HSPIQ_in/_out		
	HSPIQ_in/_out		
	HSPIQ_in/_out		
	HSPIQ_in/_out		
	HSPIQ_in/_out		
	HSPIQ_in/_out		
	HSPIQ_in/_out		
	HSPIQ_in/_out		
	HSPIQ_in/_out		
JTAG	MTDI	IO12	JTAG for software debugging
	MTCK	IO13	
	MTMS	IO14	
	MTDO	IO15	

Interface	Signal	Pin	Function
SDIO Slave	SD_CLK	IO6	SDIO interface that conforms to the industry standard SDIO 2.0 card specification.
	SD_CMD	IO11	
	SD_DATA0	IO7	
	SD_DATA1	IO8	
	SD_DATA2	IO9	
	SD_DATA3	IO10	
EMAC	EMAC_TX_CLK	IO0	Ethernet MAC with MII/RMII interface
	EMAC_RX_CLK	IO5	
	EMAC_TX_EN	IO21	
	EMAC_TXD0	IO19	
	EMAC_TXD1	IO22	
	EMAC_TXD2	IO14	
	EMAC_TXD3	IO12	
	EMAC_RX_ER	IO13	
	EMAC_RX_DV	IO27	
	EMAC_RXD0	IO25	
	EMAC_RXD1	IO26	
	EMAC_RXD2	TXD0	
	EMAC_RXD3	IO15	
	EMAC_CLK_OUT	IO16	
	EMAC_CLK_OUT_180	IO17	
	EMAC_TX_ER	IO4	
	EMAC_MDC_out	Any GPIOs*	
	EMAC_MDI_in	Any GPIOs*	
	EMAC_MDO_out	Any GPIOs*	
EMAC_CRS_out	Any GPIOs*		
EMAC_COL_out	Any GPIOs*		

**Note:**

Functions of Motor PWM, LED PWM, UART, I2C, I2S, general purpose SPI and Remote Controller can be configured to any GPIO.

## 5. Electrical Characteristics

**Note:**

The specifications in this chapter have been tested under the following general condition:  $V_{DD} = 3.3V$ ,  $T_A = 27^{\circ}C$ , unless otherwise specified.

### 5.1 Absolute Maximum Ratings

**Table 7: Absolute Maximum Ratings**

Parameter	Symbol	Min	Typ	Max	Unit
Power supply	VDD	2.3	3.3	3.6	V
Minimum current delivered by power supply	$I_{VDD}$	0.5	-	-	A
Input low voltage	$V_{IL}$	-0.3	-	$0.25 \times V_{IO}^1$	V
Input high voltage	$V_{IH}$	$0.75 \times V_{IO}^1$	-	$V_{IO}^1 + 0.3$	V
Input leakage current	$I_{IL}$	-	-	50	nA
Input pin capacitance	$C_{pad}$	-	-	2	pF
Output low voltage	$V_{OL}$	-	-	$0.1 \times V_{IO}^1$	V
Output high voltage	$V_{OH}$	$0.8 \times V_{IO}^1$	-	-	V
Maximum output drive capability	$I_{MAX}$	-	-	40	mA
Storage temperature range	$T_{STR}$	-40	-	85	$^{\circ}C$
Operating temperature range	$T_{OPR}$	-40	-	85	$^{\circ}C$

1.  $V_{IO}$  is the power supply for a specific pad. More details can be found in the [ESP32 Datasheet](#), Appendix IO\_MUX. For example, the power supply for SD\_CLK is the VDD\_SDIO.

### 5.2 Wi-Fi Radio

**Table 8: Wi-Fi Radio Characteristics**

Description	Min	Typical	Max	Unit
Input frequency	2412	-	2484	MHz
Output impedance	-	$30 + j10$	-	$\Omega$
Input reflection	-	-	-10	dB
Tx power				
Output power of PA for 72.2 Mbps	13	14	15	dBm
Output power of PA for 11b mode	19.5	20	20.5	dBm
Sensitivity				
DSSS, 1 Mbps	-	-98	-	dBm
CCK, 11 Mbps	-	-91	-	dBm
OFDM, 6 Mbps	-	-93	-	dBm
OFDM, 54 Mbps	-	-75	-	dBm
HT20, MCS0	-	-93	-	dBm

Description	Min	Typical	Max	Unit
HT20, MCS7	-	-73	-	dBm
HT40, MCS0	-	-90	-	dBm
HT40, MCS7	-	-70	-	dBm
MCS32	-	-89	-	dBm
Adjacent channel rejection				
OFDM, 6 Mbps	-	37	-	dB
OFDM, 54 Mbps	-	21	-	dB
HT20, MCS0	-	37	-	dB
HT20, MCS7	-	20	-	dB

## 5.3 BLE Radio

### 5.3.1 Receiver

Table 9: Receiver Characteristics – BLE

Parameter	Conditions	Min	Typ	Max	Unit
Sensitivity @30.8% PER	-	-	-97	-	dBm
Maximum received signal @30.8% PER	-	0	-	-	dBm
Co-channel C/I	-	-	+10	-	dB
Adjacent channel selectivity C/I	$F = F_0 + 1 \text{ MHz}$	-	-5	-	dB
	$F = F_0 - 1 \text{ MHz}$	-	-5	-	dB
	$F = F_0 + 2 \text{ MHz}$	-	-25	-	dB
	$F = F_0 - 2 \text{ MHz}$	-	-35	-	dB
	$F = F_0 + 3 \text{ MHz}$	-	-25	-	dB
	$F = F_0 - 3 \text{ MHz}$	-	-45	-	dB
Out-of-band blocking performance	30 MHz ~ 2000 MHz	-10	-	-	dBm
	2000 MHz ~ 2400 MHz	-27	-	-	dBm
	2500 MHz ~ 3000 MHz	-27	-	-	dBm
	3000 MHz ~ 12.5 GHz	-10	-	-	dBm
Intermodulation	-	-36	-	-	dBm

### 5.3.2 Transmitter

Table 10: Transmitter Characteristics – BLE

Parameter	Conditions	Min	Typ	Max	Unit
RF transmit power	-	-	0	-	dBm
Gain control step	-	-	$\pm 3$	-	dBm
RF power control range	-	-12	-	+12	dBm

Parameter	Conditions	Min	Typ	Max	Unit
Adjacent channel transmit power	F = F0 + 1 MHz	-	-14.6	-	dBm
	F = F0 - 1 MHz	-	-12.7	-	dBm
	F = F0 + 2 MHz	-	-44.3	-	dBm
	F = F0 - 2 MHz	-	-38.7	-	dBm
	F = F0 + 3 MHz	-	-49.2	-	dBm
	F = F0 - 3 MHz	-	-44.7	-	dBm
	F = F0 + > 3 MHz	-	-50	-	dBm
	F = F0 - > 3 MHz	-	-50	-	dBm
$\Delta f_{1avg}$	-	-	-	265	kHz
$\Delta f_{2max}$	-	247	-	-	kHz
$\Delta f_{2avg}/\Delta f_{1avg}$	-	-	-0.92	-	-
ICFT	-	-	-10	-	kHz
Drift rate	-	-	0.7	-	kHz/50 $\mu$ s
Drift	-	-	2	-	kHz

### 5.4 Reflow Profile

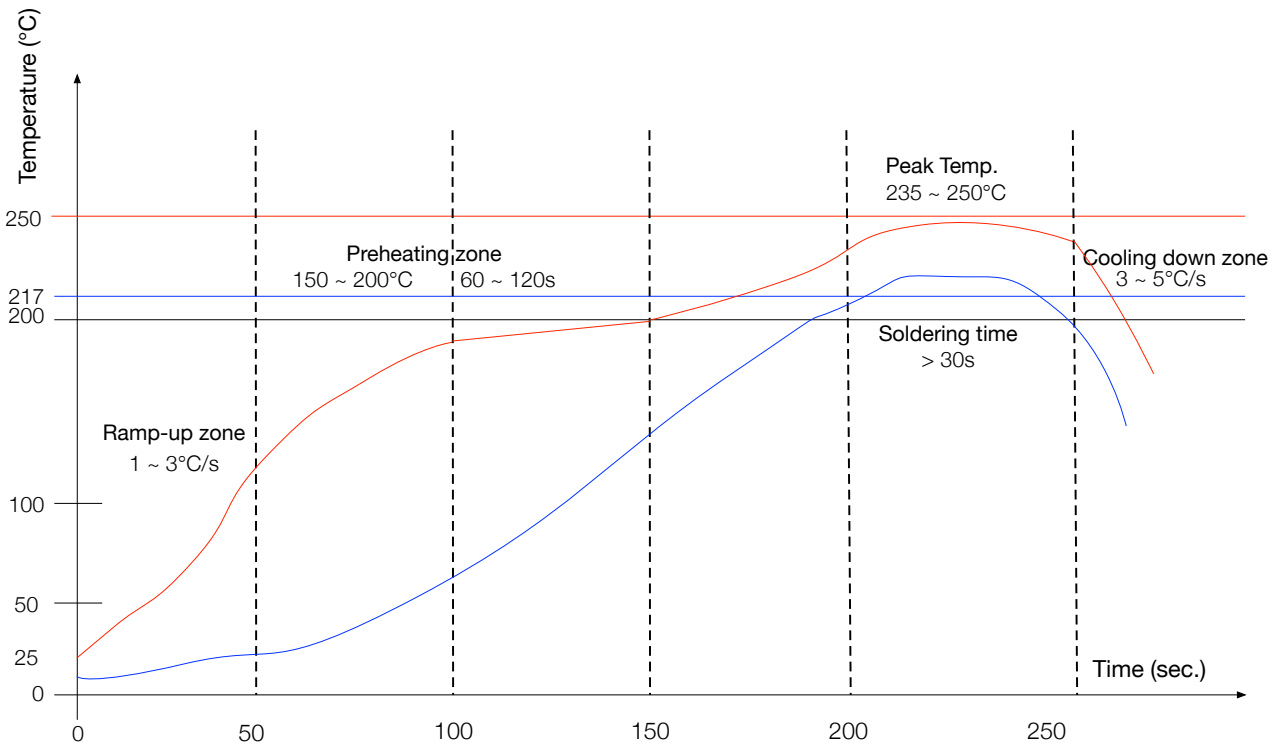

Ramp-up zone — Temp.: <150°C Time: 60 ~ 90s Ramp-up rate: 1 ~ 3°C/s  
 Preheating zone — Temp.: 150 ~ 200°C Time: 60 ~ 120s Ramp-up rate: 0.3 ~ 0.8°C/s  
 Reflow soldering zone — Peak Temp.: 235 ~ 250°C (<245°C recommended) Time: 30 ~ 70s  
 Cooling down zone — Temp.: 217 ~ 170°C Ramp-down rate: 3 ~ 5°C/s  
 Solder — Sn&Ag&Cu Lead-free solder (SAC305)

Figure 2: Reflow Profile

# 6. Schematics

ESP32 Module:with 1.8V Flash & SRAM  
 The operating voltage for signals marked in blue is 1.8V.

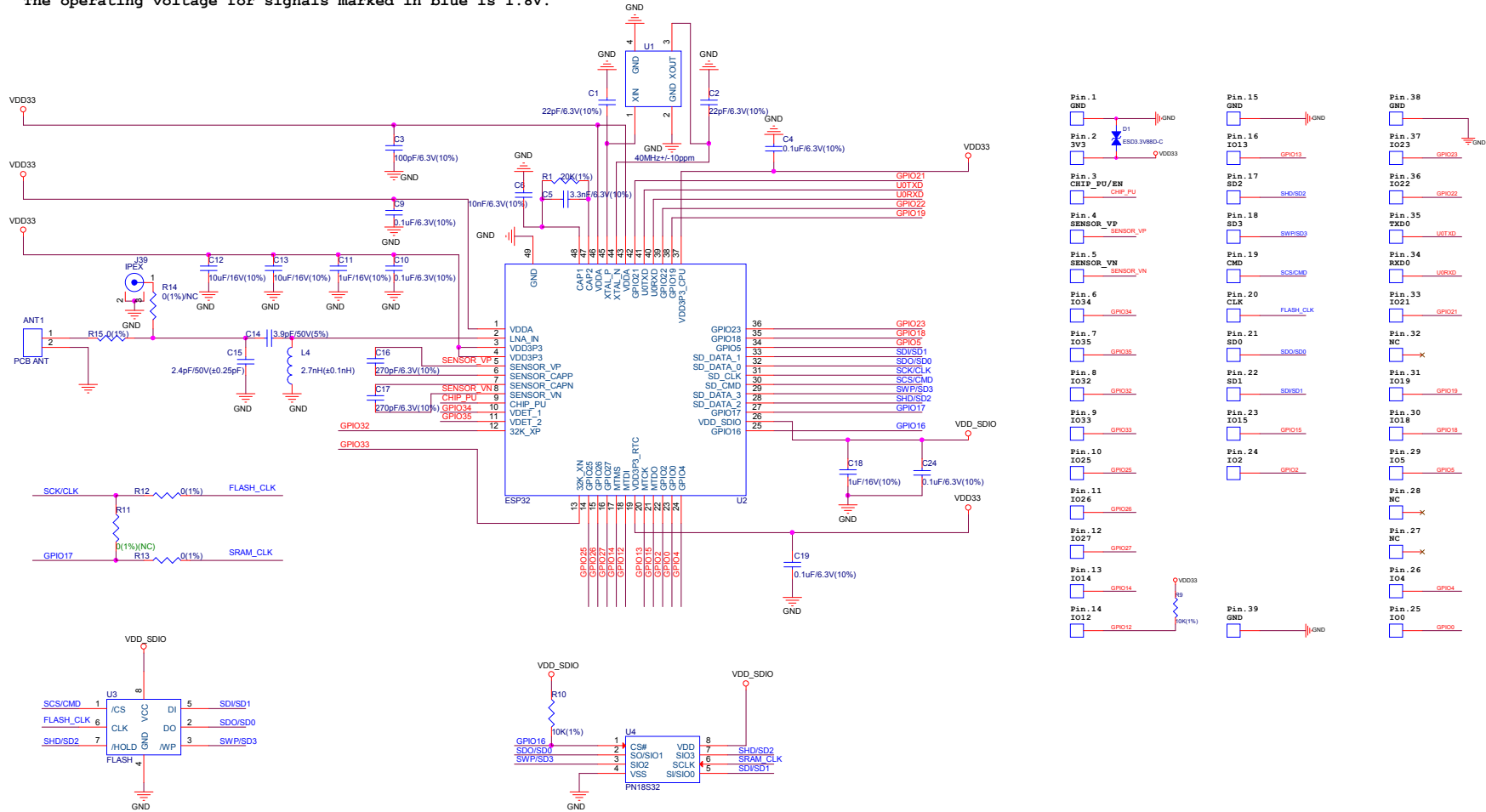

Figure 3: ESP32-WROVER Schematics

## 7. Peripheral Schematics

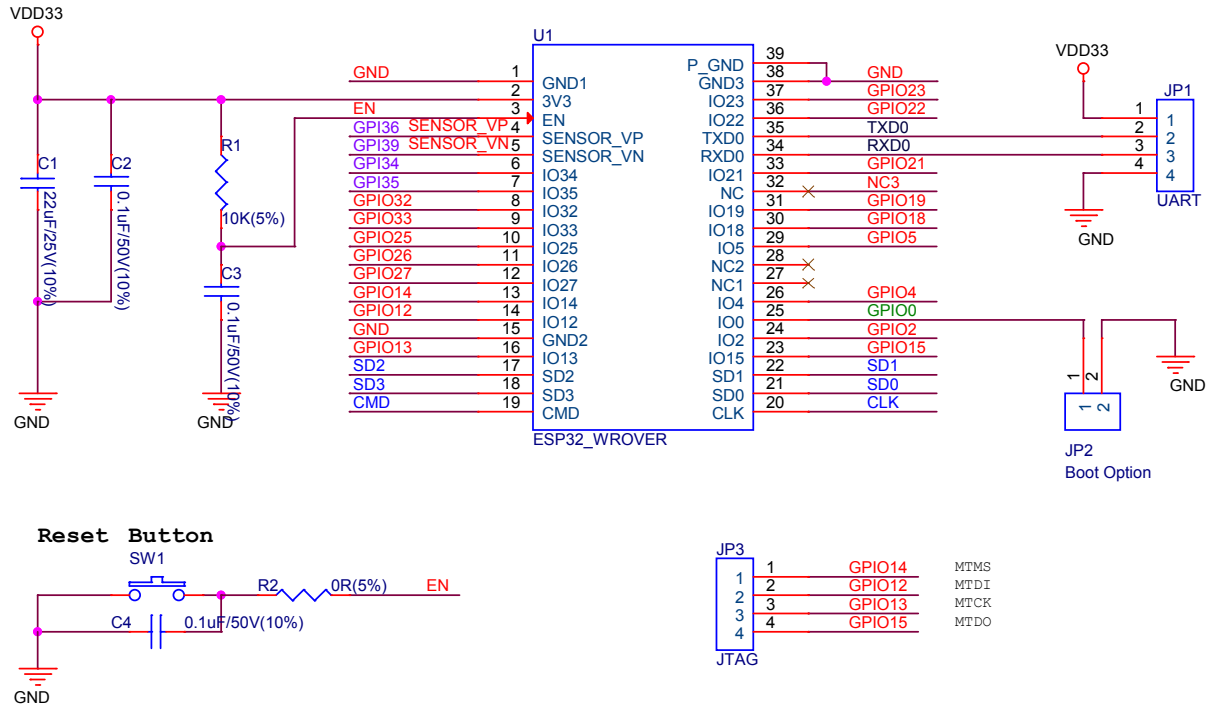

Figure 4: ESP32-WROVER Peripheral Schematics

**Note:**

It is recommended that users do not solder Pad 39 to the base board.



## 8. Dimensions

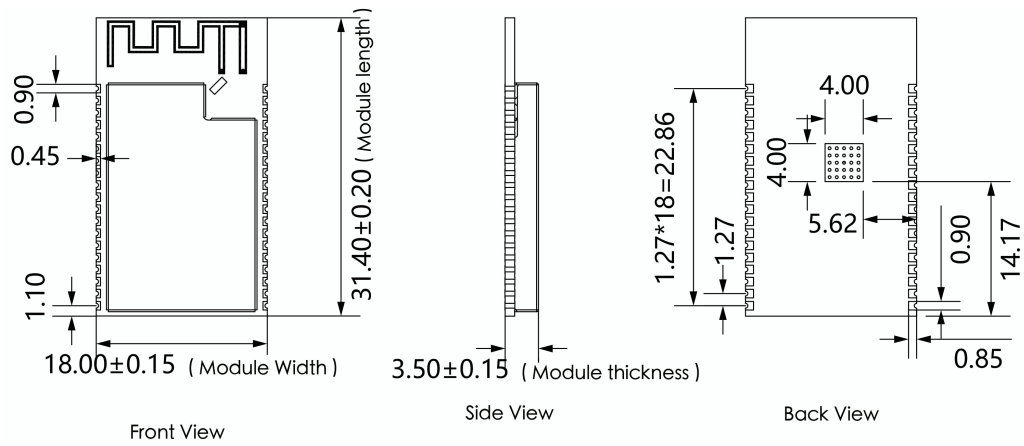

Notice: Unmarked Tolerance  $\pm 0.1$ mm

Figure 5: ESP32-WROVER Dimensions

## 9. Learning Resources

### 9.1 Must-Read Documents

The following link provides documents related to ESP32.

- [ESP32 Datasheet](#)  
This document provides an introduction to the specifications of the ESP32 hardware, including overview, pin definitions, functional description, peripheral interface, electrical characteristics, etc.
- [ESP32 Technical Reference Manual](#)  
The manual provides detailed information on how to use the ESP32 memory and peripherals.
- [ESP32 Hardware Resources](#)  
The zip files include the schematics, PCB layout, Gerber and BOM list of ESP32 modules and development boards.
- [ESP32 Hardware Design Guidelines](#)  
The guidelines outline recommended design practices when developing standalone or add-on systems based on the ESP32 series of products, including ESP32, the ESP-WROOM-32 module, and ESP32-DevKitC—the development board.
- [ESP32 AT Instruction Set and Examples](#)  
This document introduces the ESP32 AT commands, explains how to use them, and provides examples of several common AT commands.

### 9.2 Must-Have Resources

Here are the ESP32-related must-have resources.

- [ESP32 BBS](#)  
This is an Engineer-to-Engineer (E2E) Community for ESP32 where you can post questions, share knowledge, explore ideas, and help solve problems with fellow engineers.
- [ESP32 Github](#)  
ESP32 development projects are freely distributed under Espressif's MIT license on Github. It is established to help developers get started with ESP32 and foster innovation and the growth of general knowledge about the hardware and software surrounding ESP32 devices.
- [ESP32 Tools](#)  
This is a webpage where users can download ESP32 Flash Download Tools and the zip file "ESP32 Certification and Test".
- [ESP32 IDF](#)  
This webpage links users to the official IoT development framework for ESP32.
- [ESP32 Resources](#)  
This webpage provides the links to all available ESP32 documents, SDK and tools.